

SHORT STORIES

TESTI DI / TEXT BY :

STEFANIA CAMPATELLI
ALBERTO ALESSI
ETTORE SOTTASS





SHORT STORIES

2003

ETTORE SOTTASS

QUATTORDICI CERAMICHE E VETRI

FOURTEEN CERAMICS AND GLASSES

ERA IL LONTANO 1984 QUANDO PER LA PRIMA VOLTA INCONTRAI ETTORE SOTTSASS NEL SUO STUDIO A MILANO. A DIRE IL VERO LO AVEVO GIÀ VISTO A QUALCHE SUA MOSTRA E AVEVO VISTO GLI OGGETTI CHE DISEGNAVA IN QUEGLI ANNI: MOBILI COLORATISSIMI CON LA SUPERFICIE RICOPERTA DI LAMINATO PLASTICO, LAMPADE SIMILI A GIOCATTOLI, MA SOPRATTUTTO VASI.

NON SO ESATTAMENTE QUANTI VASI ABBIA DISEGNATO SOTTSASS NEGLI ULTIMI CINQUANT'ANNI, PROBABILMENTE CENTINAIA E CENTINAIA SOPRATTUTTO IN CERAMICA: LE CERAMICHE DELLE TENEBRE, LE CERAMICHE TANTRICHE, LE CERAMICHE DI FUMO ...

NEL 1984 INCONTRAI SOTTSASS PER CHIEDERGLI DI DISEGNARE ALCUNE CERAMICHE PER UN MARCHIO CHE AVEVO APPENA FONDATAO CON IL MIO COMPAGNO DI VITA. VOLEVAMO ESPORARE ATTRAVERSO I VASI L'AFFASCINANTE MONDO DEL DESIGN DI QUEGLI ANNI, FRESCHI DI ALCHIMIA, MEMPHIS.

C'ERA TANTA VOGLIA DI OGGETTI EMOZIONANTI, PROVOCANTI.

PER IL NUOVO MARCHIO FU SCELTO IL NOME "TENDENTSE", VARI DESIGNERS E ARTISTI DISEGNARONO CERAMICHE, SOTTSASS NE DISEGNÒ CINQUE, PATRIZIA SCARZELLA SCRISSE UN PICCOLO LIBRO "VASI COMUNICANTI" (IDEA BOOKS EDIZIONI, 1988) NEL CUI CAPITOLO INTRODUTTIVO INTITOLATO "QUELLA CASA INTORNO A UN VASO" ANDREA BRANZI DICEVA:

"... POTREMMO DIRE CHE UN VASO È BEN ALTRO CHE UN VASO! ESSO È UN PUNTO IN CUI L'ARTE RIPRENDE CONTATTO CON IL MONDO DEGLI UMANI, CON I DESTINI DELLA QUOTIDIANITÀ E CON GLI ORIZZONTI DELLA MEDIOCRITÀ, PIEGANDO LE GRANDI STRUTTURE DELLA STORIA SULLE FORME PANCIUTE DI QUEI CONTENITORI, DESTINATI A SOSTENERE I FIORI NELLE NOSTRE CASE.

... È INTORNO A UN VASO CHE SI COSTRUISCE LA NUOVA CASA E LA NUOVA ARCHITETTURA. CHI DISEGNA VASI, FONDA UN PENSIERO CHE ENTRA IN CASA (E NELLA STORIA)".

NEL 1990 "TENDENTSE" È STATA ACQUISITA DALLA ALESSI.

NEL 2000 HO NUOVAMENTE INCONTRATO SOTTSASS, GLI HO DETTO CHE MI SAREBBE PIACIUTO MOLTO CHE LUI DISEGNASSE DELLE NUOVE CERAMICHE, MAGARI CON DEL VETRO, DEL BEL VETRO COLORATO. I PRIMI SCHIZZI LI HA FATTI QUELL'AGOSTO A FILICUDI.

GLI ALTRI ME LI FACEVA VEDERE A PICCOLI GRUPPI QUANDO RIENTRAVA DAI SUOI VIAGGI.

ERA SEMPRE MOLTO IMPEGNATO, DUNQUE C'È VOLUTO UN PO' DI TEMPO, MA ALLA FINE, DOPO AVER FATTO UN BEL PO' DI PROTOTIPI, SIAMO ARRIVATI QUI.

RINGRAZIO TUTTI COLORO CHE HANNO COLLABORATO A QUESTA PICCOLA AVVENTURA:

ETTORE CHE HA DISEGNATO, ELENA CHE LO HA AIUTATO, MAURO E SERGIO CHE HANNO METICOLOSAMENTE MESSO A PUNTO OGNI CERAMICA E OGNI COLORE, CLAUDIO CHE - CON SIMPATICA LEGGEREZZA - MI HA FATTO CONOSCERE L'AFFASCINANTE MONDO DI MURANO, SIMONE CHE HA MESSO A DISPOSIZIONE LA SUA FORNACE, SERGIO CHE HA SOFFIATO OGNI VETRO CON MAESTRIA, FLAVIO CHE, COME SEMPRE, MI HA SUPPORTATA, GIULIA E CATERINA CHE HANNO DETTO LA LORO.

UN RINGRAZIAMENTO PARTICOLARE A ALBERTO ALESSI CHE HA TROVATO IL TEMPO PER SCRIVERE PER QUESTO LIBRO.

STEFANIA CAMPATELLI

ETTORE, IL PRIMO DESIGNER...

... CHE HO PORTATO A CRUSINALLO! NON È VERO, MA QUASI. AGLI INIZI DEGLI ANNI '70 STAVO MUOVENDO I PRIMI PASSI NEL MONDO DEL DESIGN ACCOMPAGNATO DA UN AMICO ARCHITETTO, FRANCO SARGIANI, CHE OLTRE A DISEGNARE OGGETTI PER ALESSI MI FACEVA UN PO' DI CONSULENZA DI ART DIRECTION. APPREZZAVO E APPREZZO TUTTORA LA POETICA SCARNA E PURITANA DI SARGIANI, MA SENTIVO ANCHE LA NECESSITÀ DI APRIRE LA ALESSI AD ALTRI PROGETTISTI, E CON GRANDE GENEROSITÀ FRANCO MI STAVA DANDO IL SUO AIUTO. COSÌ UN GIORNO MI PORTÒ IN FABBRICA PROPRIO ETTORE SOTTASS. CONSERVO UN FORTE RICORDO DELLA SUA VENUTA A CRUSINALLO, ERA IL PRIMO PERSONAGGIO DI STATURA INTERNAZIONALE CON IL QUALE MI CONFRONTAVO, E ARRIVAVA DA NOI PRECEDUTO DALLA REPUTAZIONE DI GURU DEL RADICAL DESIGN E DAL SUO LAVORO ALL'OLIVETTI.

ETTORE È UNA SPECIE DI FILOSOFO PIENO DI CHARME. CON LUI HO COMINCIATO A AFFRONTARE I TEMI 'ALTI' DEL DESIGN E DEL RUOLO DELL'INDUSTRIA NELLA SOCIETÀ CONTEMPORANEA. RICORDO BENE QUANDO MI AMMONÌ: "...RAGAZZO MIO NON DIMENTICARE MAI CHE IL TUO RUOLO DI INDUSTRIALE COMPORTA UNA GRANDE RESPONSABILITÀ, CHE È ANCHE UNA RESPONSABILITÀ DI NATURA CULTURALE: PER IL FATTO STESSO DI RIEMPIRE IL MONDO DI MILIONI, DECINE DI MILIONI, MILIONI DI MILIONI DI OGGETTI PRODOTTI, L'INDUSTRIA HA UNA INFLUENZA DETERMINANTE SUL NOSTRO AMBIENTE DI VITA, E QUINDI SULLA NOSTRA CULTURA!". ANCHE SE OGGI NON CI FREQUENTIAMO MOLTO, IN PARTE PER UNA SORTA DI MIA PRIVATA TIMIDEZZA, COME SE TEMESSI DI CONSUMARE LA NOSTRA RELAZIONE, E IN PARTE PERCHÉ LE NOSTRE STRADE METAPROGETTUALI SI SONO UN POCO (FORSE MOMENTANEAMENTE) DISCOSTATE, È STATO PER ME IL PRIMO MAESTRO INCONTRATO NEL QUADRO DEL MIO LAVORO. UNO DI QUEGLI INCONTRI STRAORDINARI CHE CAPITANO DI RADO NELLA VITA, CHE MI HANNO ARRICCHITO E CHE MI FANNO RITENERE UN UOMO FORTUNATO. E UN RIFERIMENTO CHE CONTINUA A ESSERE BEN PRESENTE NELLA MIA ATTIVITÀ DI DESIGN MANAGEMENT.

ALBERTO ALESSI

MOLTI ANNI FA MI È VENUTO TRA LE MANI UN GRANDE LIBRO CON FOTOGRAFIE DI CERAMICHE AZTECHE. I COLORI SU QUELLE CERAMICHE ERANO COLORI CHIARI, MOLTO OPACHI E POLVEROSI COME SE PER LE LORO CERAMICHE GLI AZTECHI AVESSERO USATO CIPRIE COLORATE AL POSTO DI SMALTI VETROSI. QUELLA IDEA DI OGGETTI COSÌ SOFFICI, COSÌ FRAGILI, COSÌ PROVVISORI CHE “APPARIVANO” NEI LUOGHI PIÙ CHE “ESISTERE” NEI LUOGHI, MI AVEVA MOLTO AFFASCINATO. SE UN OGGETTO È FRAGILE SI È COSTRETTI A GUARDARLO CON GRANDE CONCENTRAZIONE, SI È COSTRETTI A TOCCARLO CON MOLTA ATTENZIONE, SI È COSTRETTI AD AVVICINARSI CON RISPETTO COME SI FA CON QUALUNQUE COSA DI ESTREMAMENTE PREZIOSO CHE PUÒ ROMPERSI IN MILLE PEZZI E SPARIRE DA UN MOMENTO ALL'ALTRO.

HO CERCATO PER ANNI DI CAPIRE COME SI SAREBBERO POTUTE FARE CERAMICHE CHE RIPRENDESSERO L'IDEA DI QUELLE ANTICHE AZTECHE MA NON SONO MAI RIUSCITO A TROVARE UNA SOLUZIONE. HO ANCHE PENSATO CHE FORSE IL FASCINO DI QUELLE CERAMICHE AZTECHE VENIVA DALLA LORO ANTICHITÀ, DAL FATTO CHE I LORO COLORI SI ERANO OSSIDATI O SBIADITI O SEMPLICEMENTE SFALDATI NEL TEMPO COME È SUCCESSO AI COLORI NELLE LORO ARCHITETTURE, NELLE LORO STANZE E NELLE LORO TOMBE AFFRESCATE.

FORSE NON ERANO LE LORO TECNICHE CHE MI COMMUOVEVANO MA I LORO FANTASMI. AD OGNI MODO HO CONTINUATO A PENSARE ALLA POSSIBILITÀ DI FARE QUALCHE CERAMICA CHE NON RIPETESSE NECESSARIAMENTE L'IDEA ORIENTALE (MA ANCHE OCCIDENTALE) DI USARE SMALTI VETROSI CON LA SPERANZA DI DEPOSITARE PIÙ O MENO L'OGGETTO NELL'ETERNITÀ.

A FORZA DI PENSARE MI È VENUTO IN MENTE CHE FORSE POTEVO ANCHE USARE COLORI A FREDDO, FORSE NON POLVEROSI E SOFFICI COME LA CIPRIA MA AD OGNI MODO OPACHI. HO PENSATO A COLORI OPACHI SENZA NEANCHE UN PO' DI VETRO O DI LUCIDO, SENZA ALCUN RIFLESSO COSÌ CHE UNO PUÒ MISURARE LA DISTANZA TRA LA PROPRIA PELLE E LA SUPERFICIE COLORATA O INVECE -CON CERTI COLORI- UNO NON PUÒ MAI MISURARLA, LA DISTANZA, PERCHÉ L'OCCHIO SPROFONDA NEL VUOTO TOTALE DELLA SUPERFICIE SENZA SENSO; NEL VUOTO ALL'INFINITO.

HO PENSATO CHE I COLORI ACRILICI SAREBBERO ANDATI BENE PER AVERE SUPERFICI OPACHE, MOLTO OPACHE. HO PENSATO CHE UNA GRANDE QUANTITÀ DELLA PITTURA E “ARTE” DEL SECOLO APPENA PASSATO È STATA DIPINTA CON COLORI ACRILICI SUPPOSTI DI ESSERE “QUASI” ETERNI. SE POI NON SARANNO QUASI ETERNI FORSE NEL TEMPO ARRIVERANNO ANCHE LORO A UNA SPECIALE BELLEZZA: QUALCHE COLORE SBIADIRÀ, QUALCHE COLORE NO, QUALCHE ALTRO COLORE DIVENTERÀ PIÙ CUPO, NERASTRO, ALLA FINE TUTTI I COLORI DIVENTERANNO I COLORI DI QUALCHE FANTASMA, DI QUALCHE AMATA MEMORIA.

COME È SUCCESSO ALLE CERAMICHE AZTECHE...

POTREI ANCHE PARLARE DELLE COLLE NUOVE E POTENTI CHE FORSE GLI AZTECHI NON AVEVANO E CHE INVECE PERMETTONO DI ATTACCARE INSIEME PEZZI DI CERAMICA OPACA E PEZZI DI CERAMICA LUCENTE, PEZZI GRANDI DI CERAMICA E PEZZI PICCOLI, ATTACCARE PEZZI SECONDO ASSI PREVISTI E ASSI IMPREVISTI; PERMETTONO ANCHE DI ATTACCARE PEZZI DI CERAMICA CON PEZZI DI VETRO, CON PEZZI DI MARMO, DI METALLO, DI TUTTO QUELLO CHE SI VUOLE...

MA ADESSO SONO UN PO' STANCO E POI NON SI PUÒ MAI “SPIEGARE” TUTTO. ANZI, NON SI PUÒ MAI SPIEGARE NIENTE.

PERCHÉ NON LASCIARE SPAZI LIBERI, TUTTI GLI SPAZI CHE ESISTONO, A CHI GUARDA?

ETTORE SOTTSASS



CUCULO





MERLO



↑ VETRO NERO

↑ VETRO GIALLO
LIMONE

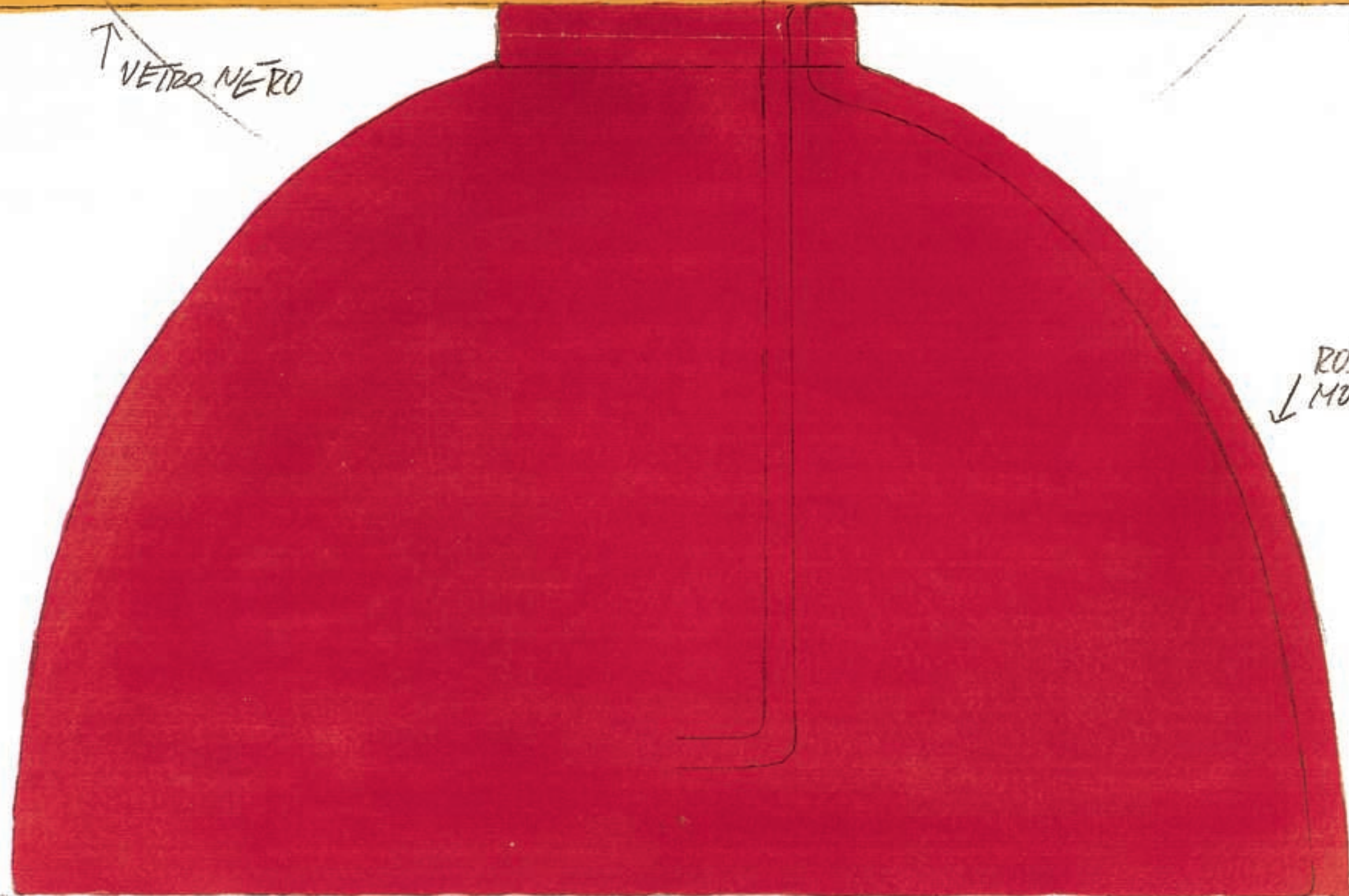

↓ ROSSO CINABRO
MOLTO LUCIDO

↓ BIANCO
MATT





TORTORA





GANGA







PETTIROSSO

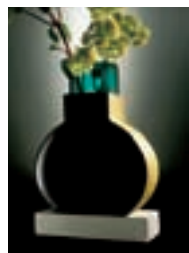

GRIFONE



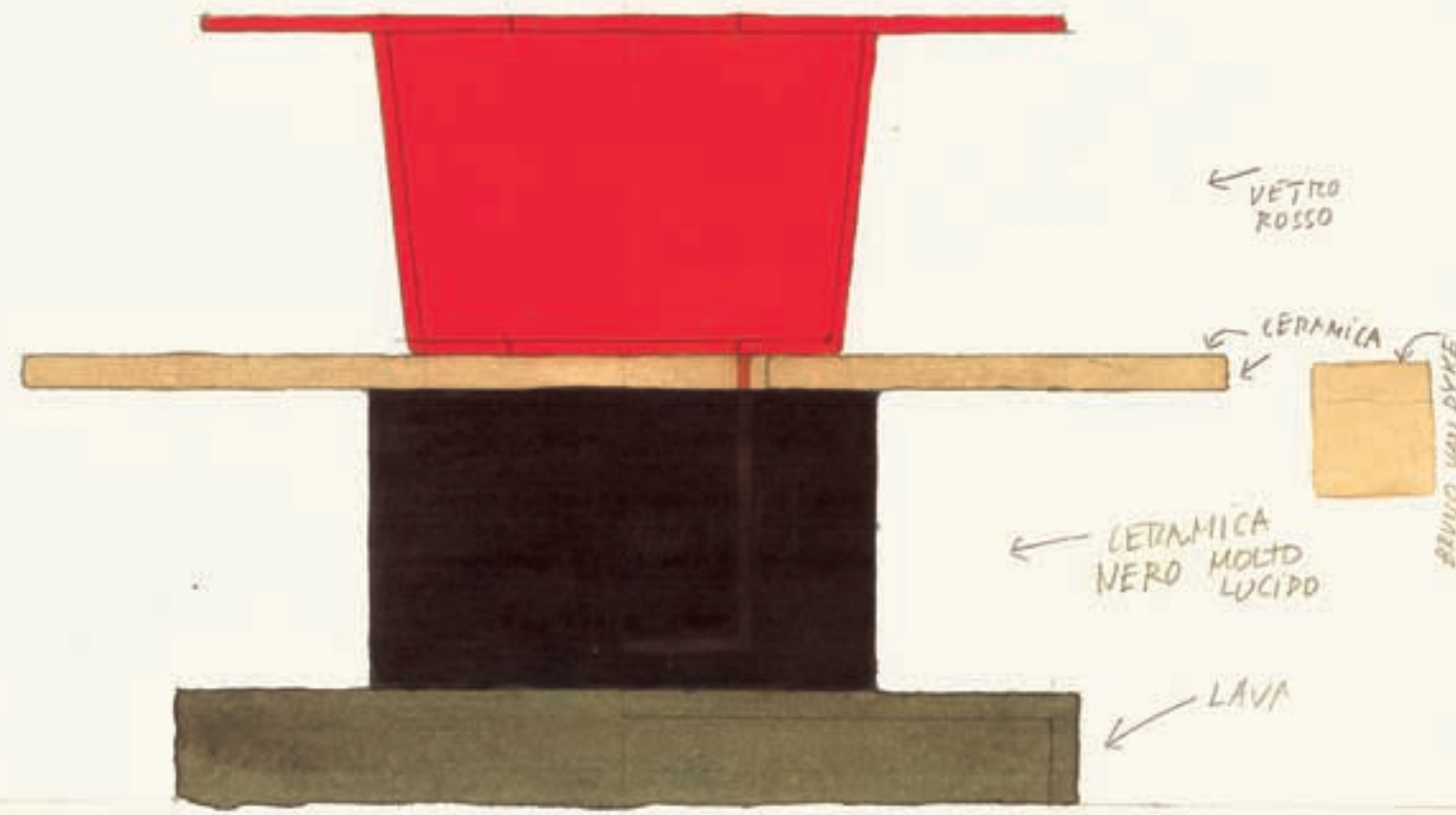



IBIS

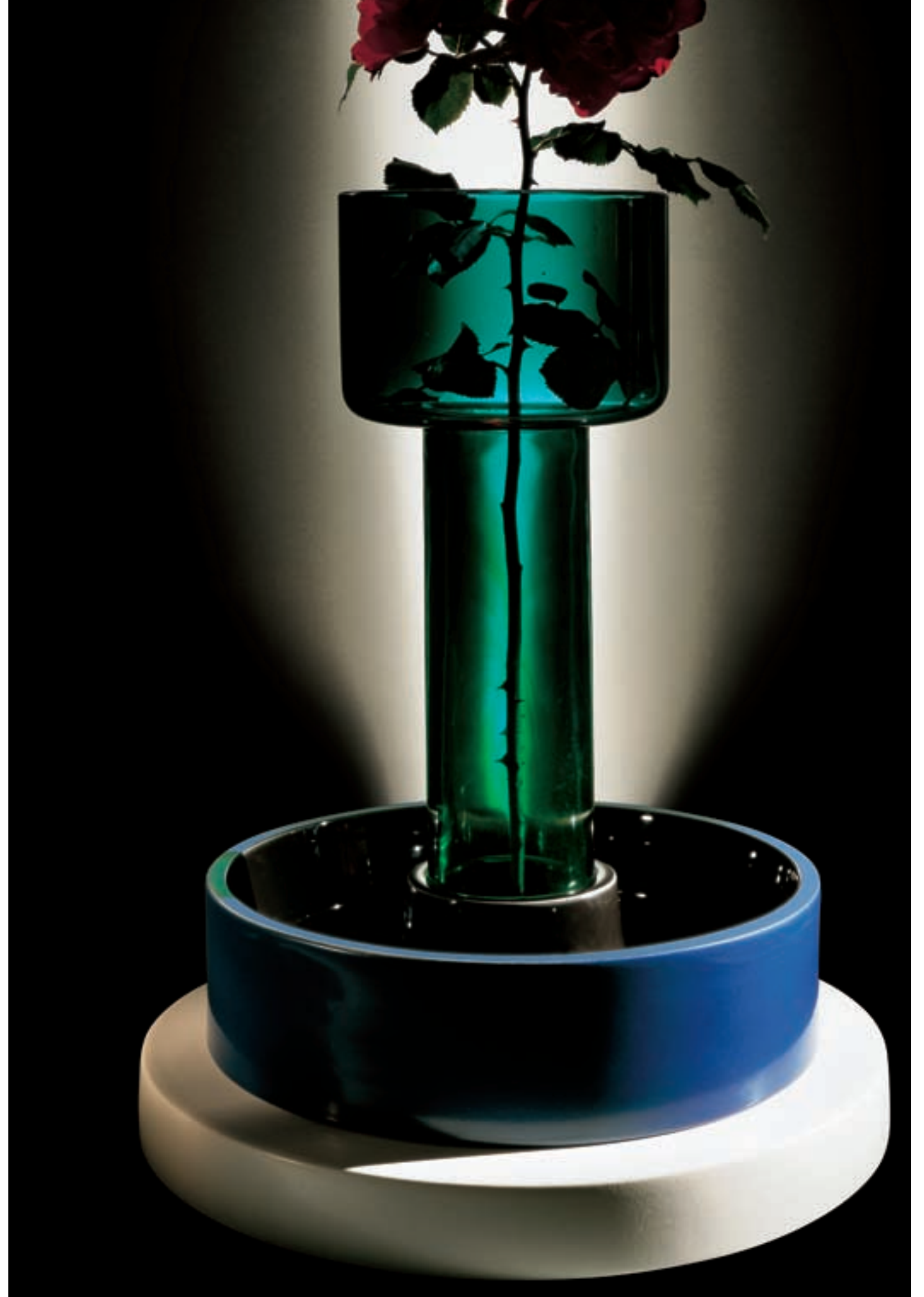



CIVETTA

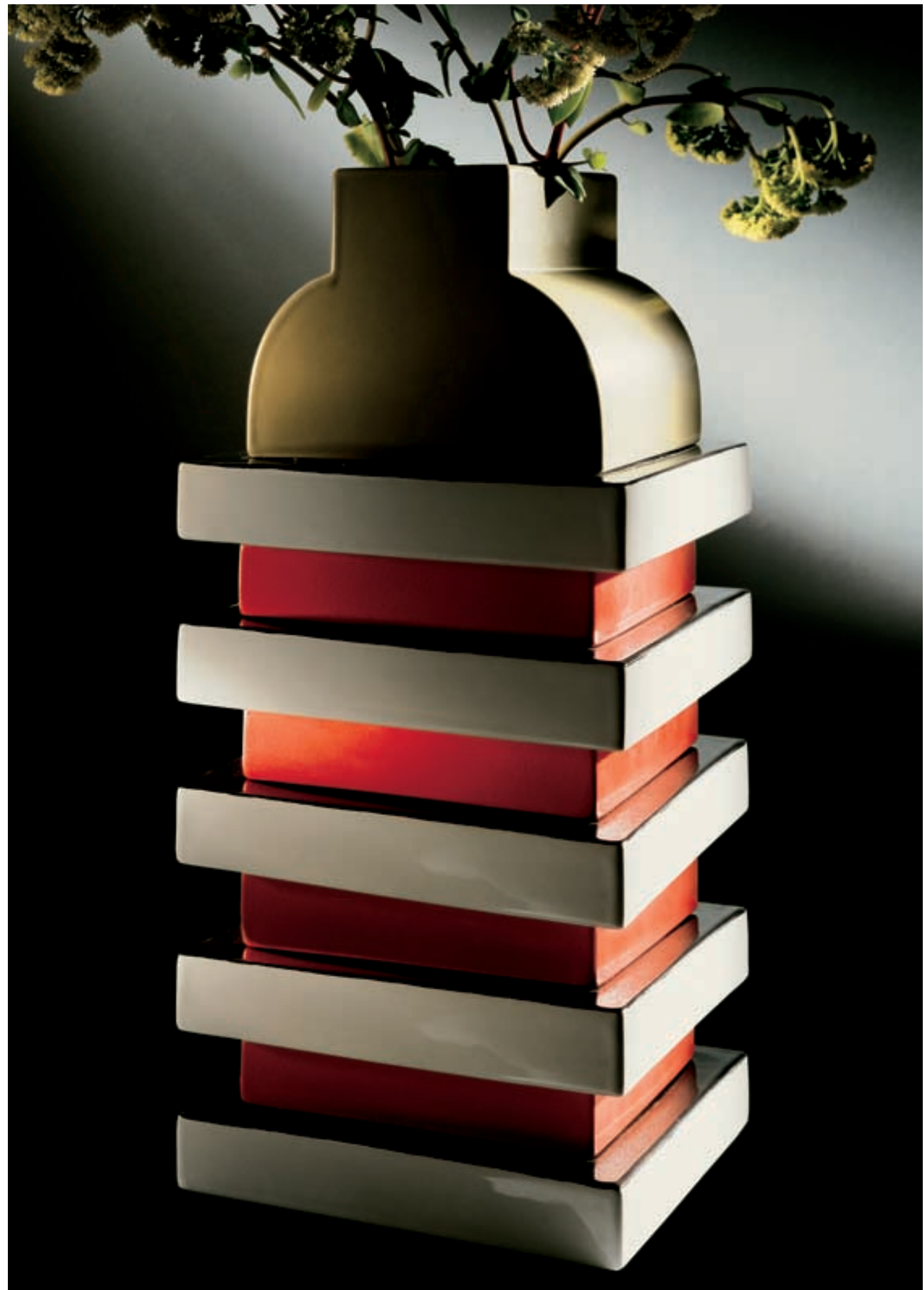





PICCHIO



UPUA

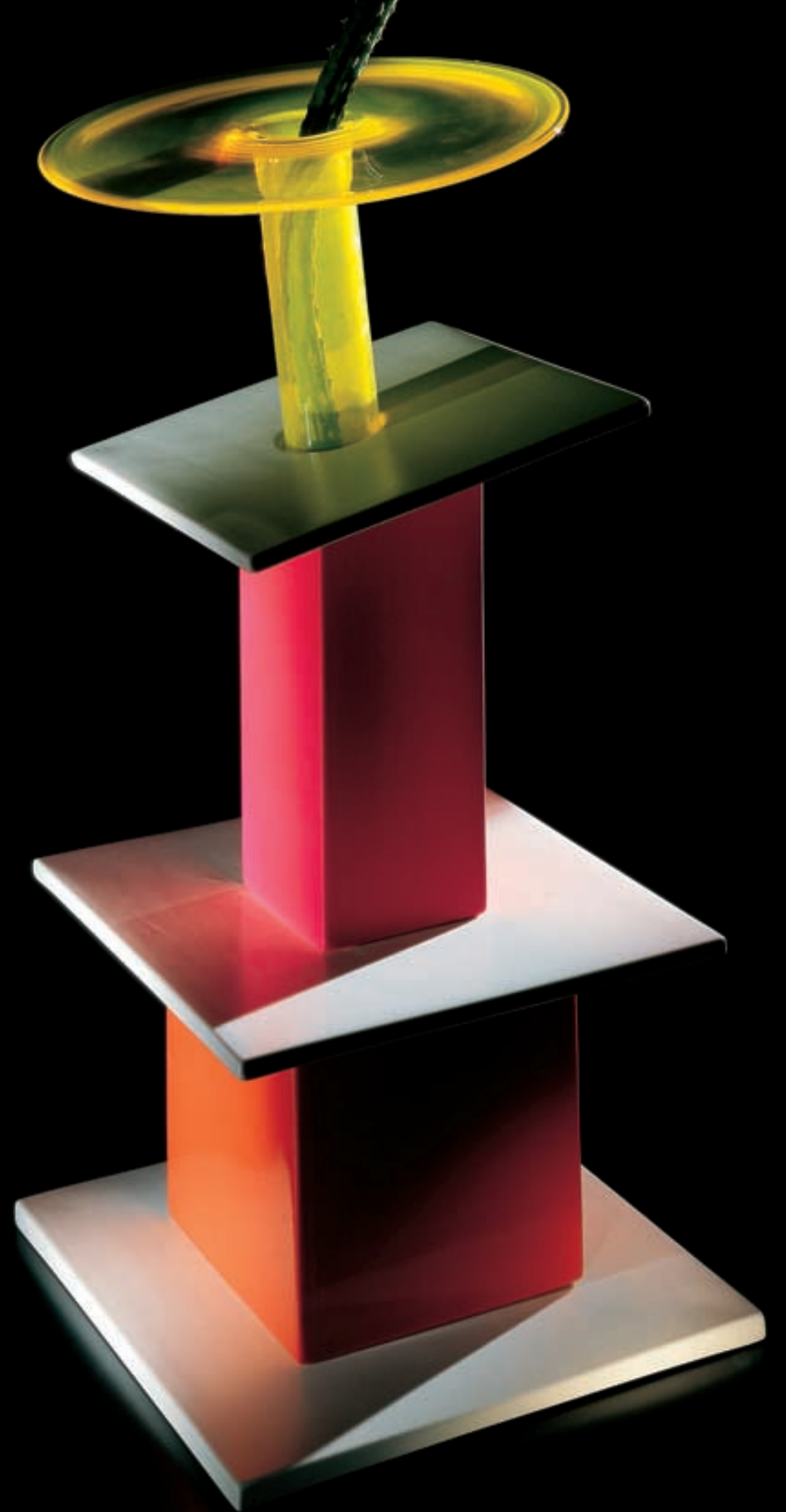





TORDO





MARABÙ



Handwritten text on the left margin, possibly a page number or reference code, including the number '41'.

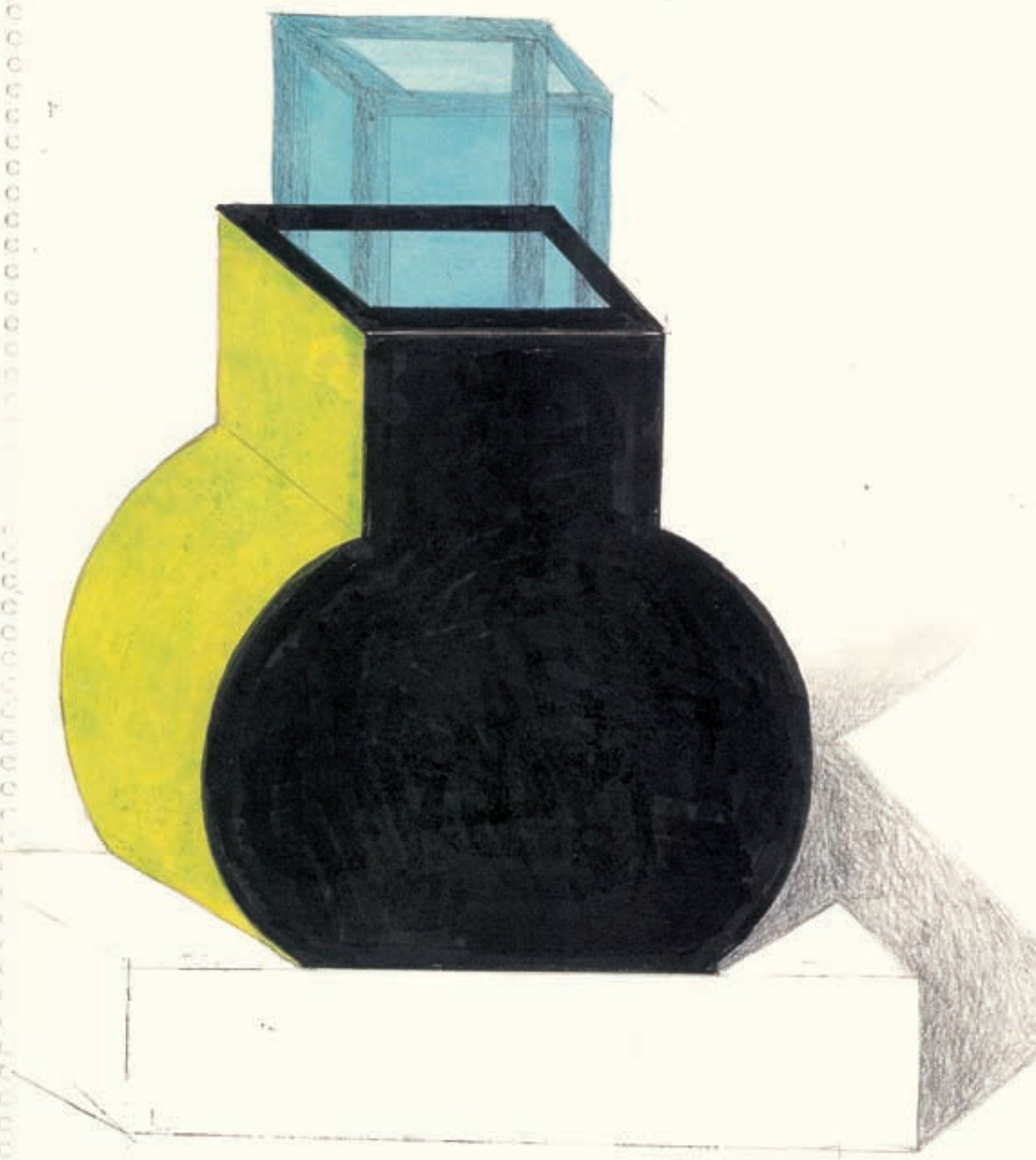



AIRONE





ALLODOLA

IT WAS BACK IN 1984 WHEN I FIRST MET ETTORE SOTTASS IN HIS STUDIO IN MILAN. ACTUALLY, I HAD ALREADY MET HIM AT SOME OF HIS EXHIBITIONS AND HAD SEEN THE OBJECTS HE DESIGNED IN THOSE YEARS: VERY COLOURFUL FURNITURE WITH PLASTIC LAMINATE TOPS, LAMPS RESEMBLING TOYS, AND ABOVE ALL VASES.

I DON'T KNOW HOW MANY VASES SOTTASS HAS DESIGNED IN THE LAST FIFTY YEARS, PROBABLY HUNDREDS AND HUNDREDS MOSTLY IN CERAMIC: THE CERAMICS OF DARKNESS, THE TANTRA CERAMICS AND THE CERAMICS OF SMOKE ...

IN 1984 I ASKED SOTTASS TO DESIGN SOME CERAMICS FOR A BRAND I HAD JUST SET UP TOGETHER WITH MY PARTNER IN LIFE. THROUGH THE VASE WE WANTED TO EXPLORE THE ATTRACTIVE WORLD OF DESIGN CHARACTERIZING THOSE YEARS, FRESH FROM ALCHIMIA AND MEMPHIS.

THERE WAS A GREAT DESIRE FOR EXCITING AND PROVOCATIVE ITEMS.

"TENDENTSE" WAS THE NAME GIVEN TO THIS NEW BRAND AND VARIOUS DESIGNERS AND ARTISTS DESIGNED CERAMICS. SOTTASS DESIGNED FIVE PIECES. PATRIZIA SCARZELLA WROTE A LITTLE BOOK TITLED "COMMUNICATING VASES" (IDEA BOOKS EDIZIONI, 1988), WHOSE INTRODUCTORY CHAPTER "THE HOUSE AROUND A VASE", WRITTEN BY ANDREA BRANZI, READ:

"... WE MIGHT SAY THAT A VASE IS MUCH MORE THAN A VASE! IT IS THE POINT AT WHICH ART COMES BACK INTO CONTACT WITH THE WORLD OF MAN, WITH THE DESTINIES OF ORDINARY LIFE AND THE VAST HORIZONS OF MEDIOCRITY, MOULDING THE GREAT STRUCTURES OF HISTORY TO FIT THE ROUNDED BELLIES OF THESE HOUSEHOLD FLOWER CONTAINERS.

... IT IS AROUND A VASE THAT WE WILL BE BUILDING A NEW HOUSE AND A NEW ARCHITECTURE. A PERSON WHO DESIGNS A VASE GENERATES AN IDEA THAT BECOMES PART OF THE HOUSE (AND OF HISTORY)."

IN 1990 ALESSI PURCHASED "TENDENTSE".

I MET SOTTASS IN 2000 AGAIN AND TOLD HIM I WOULD HAVE LIKED HIM TO DESIGN NEW CERAMICS, POSSIBLY WITH SOME GLASS, NICE AND COLOURFUL GLASS. HE MADE THE FIRST SKETCHES IN FILICUDI THAT AUGUST ALREADY.

HE WOULD SHOW ME THE OTHERS LITTLE BY LITTLE WHEN HE CAME BACK FROM HIS JOURNEYS.

HE WAS ALWAYS VERY BUSY AND WE THEREFORE NEEDED SOME TIME BUT EVENTUALLY AND AFTER MAKING A GREAT NUMBER OF PROTOTYPES WE CAME TO THIS POINT.

I WOULD LIKE TO THANK ALL THOSE PEOPLE WHO HAVE BEEN INVOLVED IN THIS LITTLE ADVENTURE: ETTORE WHO DESIGNED, ELENA WHO HELPED HIM, MAURO AND SERGIO WHO CAREFULLY CARRIED OUT EACH CERAMIC ITEM AND COLOUR, CLAUDIO WHO INTRODUCED ME – WITH KIND LIGHTNESS – TO THE FASCINATING WORLD OF MURANO, SIMONE WHO PUT HIS FURNACE AT OUR DISPOSAL, SERGIO WHO BLEW EACH GLASS WITH GREAT MASTERY, FLAVIO WHO SUPPORTED ME AS USUAL, GIULIA AND CATERINA WHO GAVE THEIR OPINION.

A SPECIAL THANKS GOES TO ALBERTO ALESSI WHO FOUND THE TIME TO WRITE A TEXT FOR THIS BOOK.

STEFANIA CAMPATELLI

ETTORE WAS THE FIRST DESIGNER...

... I BROUGHT TO CRUSINALLO! THIS IS NOT COMPLETELY TRUE. IN THE EARLY 70S I WAS TAKING MY FIRST STEPS INTO THE WORLD OF DESIGN AND I WAS ACCOMPANIED BY A FRIEND OF MINE, THE ARCHITECT FRANCO SARGIANI, WHO BESIDES DESIGNING OBJECTS FOR ALESSI GAVE ME SOME GOOD ADVICES IN ART DIRECTION. I APPRECIATED AND STILL APPRECIATE SARGIANI'S SPARE AND PURITAN POETRY BUT I ALSO FELT THE NECESSITY TO OPEN ALESSI TO OTHER DESIGNERS AND FRANCO WAS HELPING ME WITH GREAT GENEROSITY. SO ONE DAY HE BROUGHT TO THE FACTORY ETTORE SOTTASS IN PERSON. I REMEMBER VERY WELL WHEN HE FIRST CAME TO CRUSINALLO. HE WAS THE FIRST PERSON OF INTERNATIONAL STANDING WITH WHOM I HAD DEALINGS AND WAS PRECEDED BY HIS REPUTATION AS GURU OF RADICAL DESIGN AND BY HIS WORK AT OLIVETTI.

ETTORE IS A SORT OF PHILOSOPHER, BURSTING WITH CHARISMA. IT WAS WITH HIM THAT I FIRST STARTED TALKING OF THE "HIGH" TOPICS OF DESIGN AND OF THE ROLE OF INDUSTRY IN OUR SOCIETY. I STILL REMEMBER WHAT HE SAID TO ME: "...MY BOY, YOU MUST NEVER FORGET THAT YOUR ROLE AS BUSINESSMAN IMPLIES A GREAT RESPONSIBILITY WHICH IS ALSO A CULTURAL RESPONSIBILITY: SIMPLY BECAUSE THE WORLD IS FILLED WITH MILLIONS, TENS OF MILLIONS, MILLIONS AND MILLIONS OF PRODUCTS, THE INDUSTRY PLAYS A VERY IMPORTANT ROLE ON OUR LIVING ENVIRONMENT AND THEREFORE ON OUR CULTURE!". ALTHOUGH WE MEET UP ONLY ONCE IN A WHILE TODAY, IN PART DUE TO A CERTAIN SHYNESS ON MY PART, AS IF I WAS AFRAID OF USING UP THE RELATIONSHIP WITH HIM, AND PROBABLY BECAUSE FOR THE MOMENT OUR METAPROJECTS HAVE TAKEN TWO DIFFERENT DIRECTIONS, HE WAS THE FIRST PERSON I MET THROUGH WORK WHO FOR ME HAS BECOME A REAL MAESTRO. IT WAS ONE OF THOSE ENCOUNTERS YOU MAKE ONCE IN YOUR LIFE, WHICH HAVE ENRICHED ME AND HAVE MADE ME FEEL A LUCKY MAN. A BEACON THAT KEEPS ON BEING A GREAT PRESENCE IN MY ACTIVITY OF DESIGN MANAGEMENT.

ALBERTO ALESSI

MANY YEARS AGO I CAME UPON A LARGE BOOK WITH PHOTOS OF AZTEC CERAMICS. THE COLOURS OF THOSE CERAMICS WERE LIGHT, VERY MATT AND DUSTY AS IF THE AZTECS USED COLOURED POWDERS INSTEAD OF VITREOUS GLAZES FOR THEIR CERAMICS. THE IDEA OF THOSE OBJECTS WHICH WERE SO SOFT, SO FRAGILE AND EPHEMERAL AND SEEMED TO "APPEAR" RATHER THAN "EXIST" ATTRACTED ME VERY MUCH. IF AN OBJECT IS FRAGILE WE MUST LOOK AT IT WITH GREAT CONCENTRATION, WE MUST TOUCH IT WITH GREAT ATTENTION AND GO NEAR IT WITH RESPECT AS WE WOULD DO WITH AN EXTREMELY PRECIOUS OBJECT WHICH COULD FALL INTO A THOUSAND PIECES AND DISAPPEAR ALL OF A SUDDEN. FOR MANY YEARS I HAVE TRIED TO UNDERSTAND HOW I COULD MAKE CERAMICS LIKE THOSE OF THE ANCIENT AZTECS BUT I HAVE NEVER BEEN ABLE TO FIND A SOLUTION. I THOUGHT THAT MAYBE I WAS FASCINATED BY THOSE AZTEC CERAMICS BECAUSE THEY WERE OLD AND THEIR COLOURS HAD OXIDIZED OR FADED OR HAD SIMPLY CHIPPED WITH THE PASSING OF TIME AS DID THE FRESCOES OF THEIR ARCHITECTURES, THEIR ROOMS AND TOMBS. PERHAPS IT WASN'T THEIR TECHNIQUES THAT MOVED ME BUT THEIR GHOSTS. ANYWAY, I HAVE KEPT ON THINKING OF THE POSSIBILITY OF MAKING CERAMICS THAT WOULDN'T NECESSARILY CONVEY THE ORIENTAL (AND OCCIDENTAL) IDEA OF USING VITREOUS GLAZES TO MAKE TIMELESS OBJECTS.

AFTER THINKING ABOUT IT FOR A LONG TIME, I SUDDENLY HAD THE IDEA OF USING COLD-FINISHED COLOURS, WHICH WEREN'T PERHAPS AS DUSTY AND SOFT AS POWDER BUT MATT ANYWAY. I HAVE CHOSEN MATT COLOURS WITHOUT ANY GLASS OR GLAZE, WITHOUT ANY REFLECTIONS SO THAT ONE COULD MEASURE THE DISTANCE BETWEEN HIS SKIN AND THE COLOURED SURFACE. HOWEVER, WITH SOME COLOURS, ONE CANNOT MEASURE THIS DISTANCE BECAUSE THE EYES WOULD SINK INTO THE COMPLETE EMPTINESS OF A MEANINGLESS SURFACE; INTO THE NEVERENDING EMPTINESS. I HAVE THOUGHT THAT ACRYLIC COLOURS WOULD BE FINE TO MAKE MATT, VERY MATT SURFACES. I HAVE THOUGHT THAT A GREAT DEAL OF PAINTINGS AND ARTWORKS OF LAST CENTURY WERE MADE WITH ACRYLIC COLOURS CONSIDERED TO BE "ALMOST" ETERNAL. EVEN IF THEY ARE NOT GOING TO BE ALMOST ETERNAL MAYBE THEY TOO WILL ACHIEVE A SPECIAL BEAUTY WITH THE PASSING OF TIME: SOME COLOURS WILL FADE, SOME WON'T, SOME OTHERS WILL BECOME DARKER, ALMOST BLACK, AT THE END ALL THE COLOURS WILL BECOME THE COLOURS OF GHOSTS, OF BELOVED MEMORIES. AS IT HAPPENED TO THE AZTEC CERAMICS...

I COULD ALSO TALK ABOUT THE NEW AND POWERFUL GLUES THAT THE AZTECS PROBABLY DIDN'T HAVE, WHICH HOWEVER ARE USED TO FIT TOGETHER MATT AND GLAZED CERAMIC PIECES, BIG AND SMALL CERAMIC PIECES, AND TO ASSEMBLE PIECES ACCORDING TO FORESEEN AND UNFORESEEN AXES; THEY ALSO ALLOW TO ASSEMBLE CERAMIC WITH GLASS, MARBLE, METAL AND EVERY OTHER MATERIAL...

BUT I AM TIRED NOW AND BESIDES WE CANNOT ALWAYS "EXPLAIN" EVERYTHING. ON THE CONTRARY, WE CAN NEVER EXPLAIN ANYTHING. WHY NOT LEAVE FREE SPACES, ALL THE EXISTING SPACES, TO THOSE WHO WATCH?

ETTORE SOTTASS

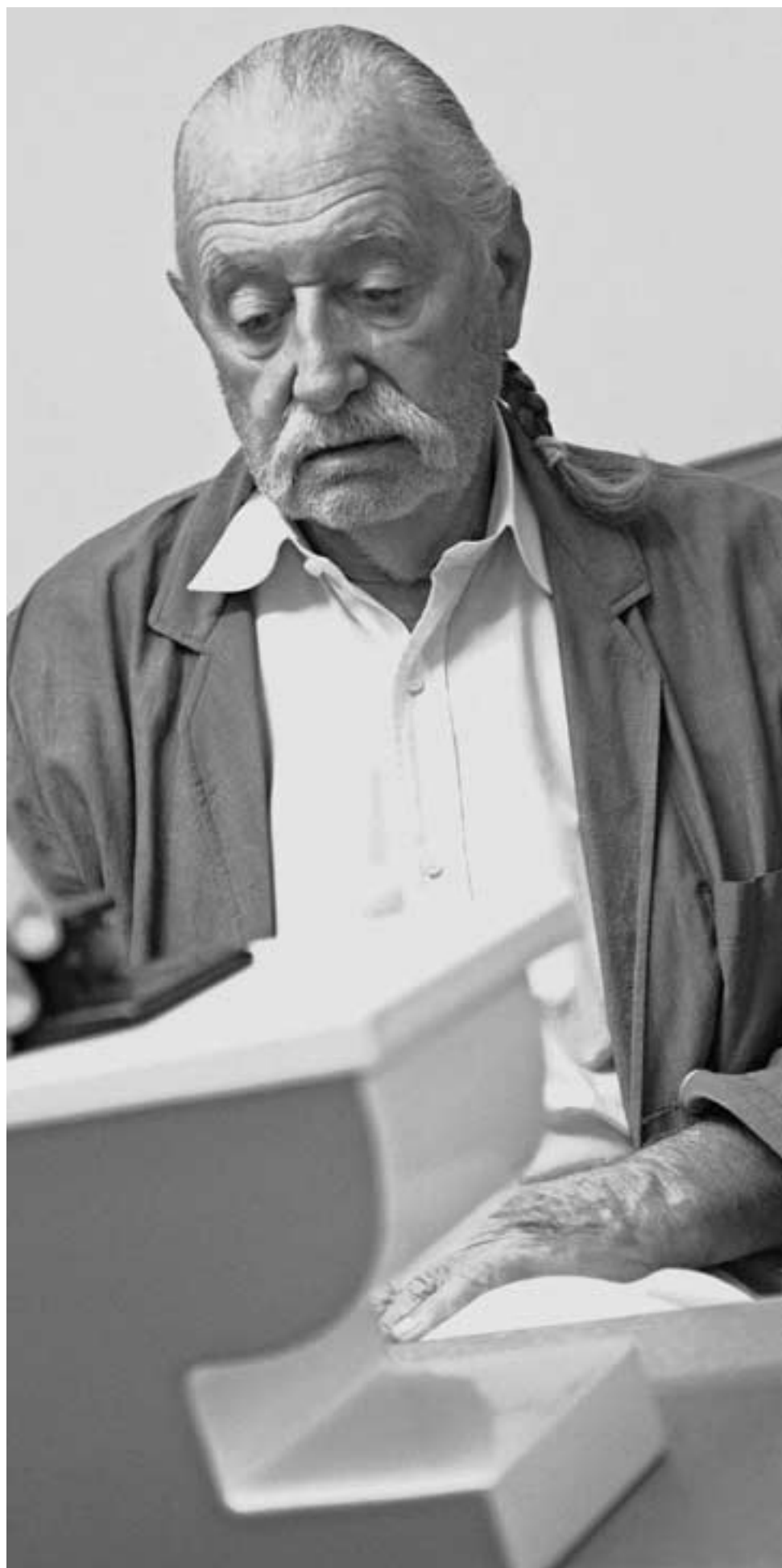

CATALOGO COMPLETO
DELLE PROVE D'AUTORE

COMPLETE CATALOGUE
WITH AUTHOR'S PROOFS



CUCULO > CERAMICA SIGLATA "SOTTASS 14.01.02"
VETRO: ETICHETTA IN CARTA 14.01.02

CUCULO > SIGNED AND DATED CERAMIC "SOTTASS 14/01/02"
GLASS: PAPER LABEL 14/01/02



CUCULO > CERAMICA SIGLATA "SOTTASS PROVA DEL 10.05.02"
VETRO: ETICHETTA IN CARTA DEL 14.01.02

CUCULO > SIGNED AND DATED CERAMIC "SOTTASS PROOF OF 10/05/02"
GLASS: PAPER LABEL OF 14/01/02



CUCULO > CERAMICA SIGLATA "SOTTASS PROVA DEL 27.06.02"
VETRO: "SHORT STORIES - SOTTASS 21.06.02 MURANO"

CUCULO > SIGNED AND DATED CERAMIC "SOTTASS PROOF OF 27/06/02"
GLASS: "SHORT STORIES - SOTTASS 21/06/02 MURANO"



CUCULO > CERAMICA SIGLATA "SOTTASS PROVA DEL 10.07.02"
VETRO: "SHORT STORIES - SOTTASS P.A. 04.07.02 MURANO"

CUCULO > SIGNED AND DATED CERAMIC "SOTTASS PROOF OF 10/07/02"
GLASS: "SHORT STORIES - SOTTASS P.A. 04/07/02 MURANO"



CUCULO > CERAMICA SIGLATA "SOTTASS PROVA DEL 10.12.02"
VETRO: "SHORT STORIES - SOTTASS 04.07.02 MURANO"

CUCULO > SIGNED AND DATED CERAMIC "SOTTASS PROOF OF 10/12/02"
GLASS: "SHORT STORIES - SOTTASS 04/07/02 MURANO"

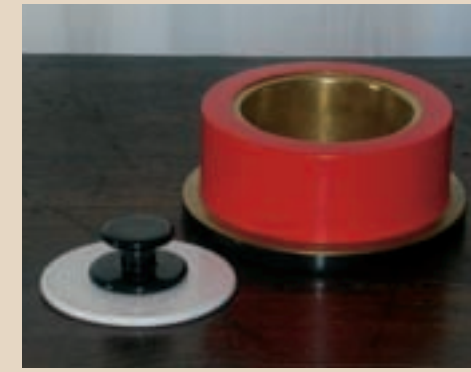

MERLO > CERAMICA SIGLATA "PROVA 04.02.02" INTERNO E BORDO ORO OPACO

MERLO > MARKED AND DATED CERAMIC "PROOF OF 04/02/02" INSIDE AND EDGE
IN MATT GOLD



MERLO > CERAMICA SIGLATA "PROVA 10.05.02" - CERAMICA "PROVA 10.05.02"
MERLO > MARKED AND DATED CERAMIC "PROOF OF 10/05/02" - CERAMIC "PROOF OF 10.05.02"



MERLO > CERAMICA SIGLATA "PROVA 04.11.02"
MERLO > CERAMIC "PROOF OF 04/11/02"



TORTORA > CERAMICA SIGLATA "SOTTASS 03.07.01"
VETRO: "SHORT STORIES - SOTTASS 04.07.02"
TORTORA > SIGNED AND DATED CERAMIC "SOTTASS 03/07/01"
GLASS: "SHORT STORIES - SOTTASS 04/07/02"



TORTORA > CERAMICA SIGLATA "PROVA 20.01.02" (BASE RIALZATA)
VETRO: "SHORT STORIES - SOTTASS 10.05.02 MURANO"
TORTORA > MARKED AND DATED CERAMIC "PROOF OF 20/01/02" (RAISED
BASE) GLASS: "SHORT STORIES - SOTTASS 10/05/02 MURANO"



TORTORA > CERAMICA SIGLATA "PROVA 10.05.02"
VETRO: "SHORT STORIES - SOTTASS 04.07.02 MURANO"
TORTORA > DATED CERAMIC "10/05/02"
GLASS: "SHORT STORIES - SOTTASS 04/07/02 MURANO"



GANGA > CERAMICA SIGLATA "PROVA 18.11.02"
VETRO INCAMICIATO SETA: ETICHETTA IN CARTA "10.12.02 MURANO"
GANGA > MARKED AND DATED CERAMIC "PROOF OF 18/11/02"
"INCAMICIATO": PAPER LABEL "10/12/02 MURANO"



GANGA > CERAMICA SIGLATA "PROVA 18.11.02"
VETRO: ETICHETTA IN CARTA "10.12.02 MURANO"
GANGA > MARKED AND DATED CERAMIC "PROOF OF 18/11/02"
GLASS: PAPER LABEL "10/12/02 MURANO"



GANGA > CERAMICA SIGLATA "PROVA 06.12.02" VETRO INCAMICIATO BIANCO; ETICHETTA IN CARTA "10.12.02 MURANO"

GANGA > MARKED AND DATED CERAMIC "PROOF OF 06/12/02" WHITE GLASS "INCAMICIATO"; PAPER LABEL "10/12/02 MURANO"

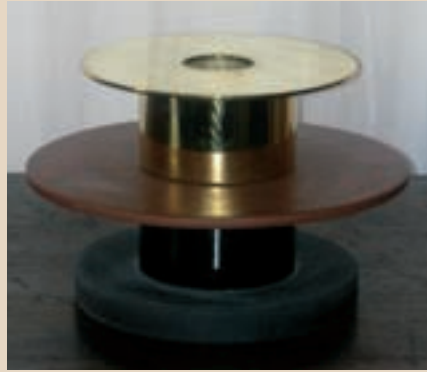

PETTIROSSO > CERAMICA ETICHETTA IN CARTA "01.03.02" OTTONE PER STUDIO FORMA CORPO CILINDRICO ETICHETTA IN CARTA "13.03.02"

PETTIROSSO > CERAMIC PAPER LABEL "01/03/02" BRASS FOR SHAPE STUDY CYLINDER BODY PAPER LABEL "13/03/02"



PETTIROSSO > CERAMICA ETICHETTA IN CARTA "07.05.02" VETRO: "SHORT STORIES - SOTTASS 10.05.02 MURANO"

PETTIROSSO > CERAMIC PAPER LABEL "07/05/02" GLASS: "SHORT STORIES - SOTTASS 10/05/02 MURANO"



PETTIROSSO > CERAMICA SIGLATA "PROVA 10.05.02" VETRO: ETICHETTA IN CARTA "10.05.02"

PETTIROSSO > CERAMIC "PROOF OF 10.05.02" GLASS: PAPER LABEL "10/05/02"



PETTIROSSO > CERAMICA SIGLATA "PROVA 25.06.01" BASE "LAVA" VETRO: "SHORT STORIES - SOTTASS 10.05.02 MURANO"

PETTIROSSO > MARKED AND DATED CERAMIC "PROOF OF 25/06/01" "LAVA" BASE GLASS: "SHORT STORIES - SOTTASS 10/05/02 MURANO"



PETTIROSSO > CERAMICA ETICHETTA IN CARTA "25.06.02" VETRO: ETICHETTA IN CARTA "10.05.02" (CORPO TRONCO-CONICO)

PETTIROSSO > CERAMIC PAPER LABEL "25/06/02" GLASS: PAPER LABEL "10/05/02" (TRUNCATED CONIC BASE)



GRIFONE > CERAMICA SIGLATA "PROVA 30.01.02" VETRO: "SHORT STORIES SOTTASS 04.07.02 MURANO"

GRIFONE > MARKED AND DATED CERAMIC "PROOF OF 30/01/02" GLASS: "SHORT STORIES - SOTTASS 04/07/02 MURANO"



GRIFONE > CERAMICA SIGLATA "PROVA 10.05.02" VETRO: "SHORT STORIES SOTTASS 21.06.02 MURANO"

GRIFONE > MARKED AND DATED CERAMIC "PROOF OF 10/05/02" GLASS: "SHORT STORIES - SOTTASS 21/06/02 MURANO"



GRIFONE > CERAMICA SIGLATA "PROVA 10.06.02" VETRO: "SHORT STORIES SOTTASS 10.05.02 MURANO"

GRIFONE > MARKED AND DATED CERAMIC "PROOF OF 10/06/02" GLASS: "SHORT STORIES - SOTTASS 10/05/02 MURANO"



IBIS > CERAMICA SIGLATA "PROVA 29.01.02" VETRO: ETICHETTA IN CARTA "22.01.02"

IBIS > MARKED AND DATED CERAMIC "PROOF OF 29/01/02" GLASS: PAPER LABEL "22/01/02"



IBIS > CERAMICA SIGLATA "PROVA 21.02.02" VETRO: ETICHETTA IN CARTA "27.02.02 MURANO"

IBIS > MARKED AND DATED CERAMIC "PROOF OF 21/02/02" GLASS: PAPER LABEL "27/02/02 MURANO"



IBIS > CERAMICA SIGLATA "PROVA 10.10.02" VETRO: ETICHETTA IN CARTA "10.05.02 MURANO"

IBIS > MARKED AND DATED CERAMIC "PROOF OF 10/10/02" GLASS: PAPER LABEL "10/05/02 MURANO"



IBIS > CERAMICA SIGLATA "PROVA 10.05.02" VETRO: ETICHETTA IN CARTA "10.05.02 MURANO"

IBIS > MARKED AND DATED CERAMIC "PROOF OF 10/05/02" GLASS: PAPER LABEL "10/05/02 MURANO"



CIVETTA > CERAMICA SIGLATA "PROVA 10.05.02"

CIVETTA > MARKED AND DATED CERAMIC "PROOF OF 10/05/02"



CIVETTA > CERAMICA SIGLATA "PROVA 10.05.02"

CIVETTA > MARKED AND DATED CERAMIC "PROOF OF 10/05/02"



CIVETTA > CERAMICA SIGLATA "PROVA 10.05.02"

CIVETTA > MARKED AND DATED CERAMIC "PROOF OF 10/05/02"



PICCHIO > CERAMICA SIGLATA "PROVA 22.01.02"
PICCHIO > MARKED AND DATED CERAMIC "PROOF OF 22/01/02"

PICCHIO > CERAMICA SIGLATA "PROVA 22.10.02"
PICCHIO > MARKED AND DATED CERAMIC "PROOF OF 22/10/02"

PICCHIO > CERAMICA SIGLATA "PROVA 22.11.01"
PICCHIO > MARKED AND DATED CERAMIC "PROOF OF 22/11/01"

UPUPA > CERAMICA SIGLATA "PROVA 13.11.02"
VETRO: ETICHETTA IN CARTA "13.11.02 MURANO"
UPUPA > MARKED AND DATED CERAMIC "PROOF OF 13/11/02"
GLASS: PAPER LABEL "13/11/02 MURANO"

UPUPA > CERAMICA SIGLATA "PROVA 05.11.02"
VETRO: ETICHETTA IN CARTA "13.11.02 MURANO"
UPUPA > MARKED AND DATED CERAMIC "PROOF OF 05/11/02"
GLASS: PAPER LABEL "13/11/02 MURANO"

UPUPA > CERAMICA SIGLATA "PROVA 10.12.02"
VETRO: ETICHETTA IN CARTA "13.11.02 MURANO"
UPUPA > MARKED AND DATED CERAMIC "PROOF OF 10/12/02"
GLASS: PAPER LABEL "13/11/02 MURANO"

UPUPA > CERAMICA SIGLATA "PROVA 18.11.02"
VETRO: ETICHETTA IN CARTA "13.11.02 MURANO"
UPUPA > MARKED AND DATED CERAMIC "PROOF OF 18/11/02"
GLASS: PAPER LABEL "13/11/02 MURANO"

UPUPA > CERAMICA SIGLATA "PROVA 01.11.02"
VETRO: ETICHETTA IN CARTA "13.11.02 MURANO"
UPUPA > MARKED AND DATED CERAMIC "PROOF OF 01/11/02"
GLASS: PAPER LABEL "13/11/02 MURANO"



TORDO > CERAMICA SIGLATA "PROVA 26.01.02"
TORDO > MARKED AND DATED CERAMIC "PROOF OF 26/01/02"



TORDO > CERAMICA SIGLATA "PROVA 10.02.02" CON INTERNO ORO LUCIDO
CERAMICA "10.02.02" CON INTERNO ORO OPACO
TORDO > MARKED AND DATED CERAMIC "PROOF OF 10/02/02" WITH INSIDE IN GLOSSY GOLD - CERAMIC "10/02/02" WITH INSIDE IN MATT GOLD



TORDO > CERAMICA SIGLATA "PROVA 26.01.02" CON PRIMA VERSIONE COPERCHIO
TORDO > MARKED AND DATED CERAMIC "PROOF OF 26/01/02" WITH FIRST VERSION LID



TORDO > CERAMICA SIGLATA "PROVA 10.05.02" CON COPERCHIO DEFINITIVO
TORDO > MARKED AND DATED CERAMIC "PROOF 10/05/02" WITH DEFINITIVE LID



MARABU > CERAMICA SIGLATA "PROVA 20.10.02"
VETRO: ETICHETTA IN CARTA "10.05.02 MURANO"
MARABU > MARKED AND DATED CERAMIC "PROOF OF 20/10/02" GLASS: PAPER LABEL "10/05/02 MURANO"

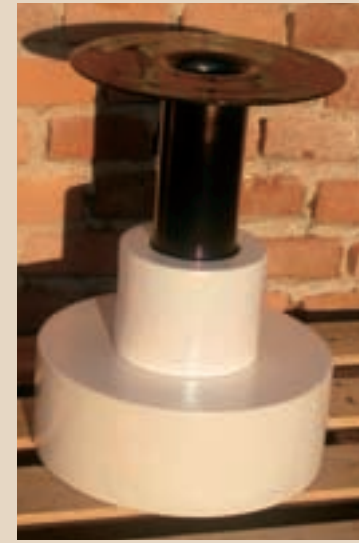

MARABU > CERAMICA SIGLATA "PROVA 22.10.02"
VETRO: ETICHETTA IN CARTA "10.05.02 MURANO"
MARABU > MARKED AND DATED CERAMIC "PROOF OF 22/10/02" GLASS: PAPER LABEL "10/05/02 MURANO"



MARABU > CERAMICA DATATA "14.11.02"
VETRO: ETICHETTA IN CARTA "10.05.02 MURANO"
MARABU > MARKED AND DATED CERAMIC "PROOF OF 14/11/02" GLASS: PAPER LABEL "10/05/02 MURANO"



AIRONE > CERAMICA SIGLATA "PROVA 20.07.02"
VETRO: ETICHETTA IN CARTA "10.07.02 MURANO"

AIRONE > MARKED AND DATED CERAMIC "PROOF OF 20/07/02"
GLASS: PAPER LABEL "10/07/02 MURANO"



AIRONE > CERAMICA SIGLATA "PROVA 18.07.02"
VETRO: ETICHETTA IN CARTA "10.07.02 MURANO"

AIRONE > MARKED AND DATED CERAMIC "PROOF OF 18/07/02"
GLASS: PAPER LABEL "10/07/02 MURANO"



AIRONE > CERAMICA SIGLATA "PROVA 16.09.02"
VETRO: ETICHETTA IN CARTA "04.09.02 MURANO"

AIRONE > MARKED AND DATED CERAMIC "PROOF OF 16/09/02"
GLASS: PAPER LABEL "04/09/02 MURANO"



ALLODOLA > CERAMICA SIGLATA "PROVA 11.11.02"
VETRO: ETICHETTA IN CARTA "04.09.02 MURANO"

ALLODOLA > MARKED AND DATED CERAMIC "PROOF OF 11/11/02"
GLASS: PAPER LABEL "04/09/02 MURANO"



ALLODOLA > CERAMICA SIGLATA "PROVA 27.11.02"
VETRO: ETICHETTA IN CARTA "13.11.02 MURANO"

ALLODOLA > MARKED AND DATED CERAMIC "PROOF OF 27/11/02"
GLASS: PAPER LABEL "13/11/02 MURANO"



ALLODOLA > CERAMICA SIGLATA "PROVA 27.11.02"
VETRO: ETICHETTA IN CARTA "13.11.02 MURANO"

ALLODOLA > MARKED AND DATED CERAMIC "PROOF OF 27/11/02"
GLASS: PAPER LABEL "13/11/02 MURANO"

NOTE TECNICHE

TECHNICAL INFORMATION

LA CERAMICA

TUTTE LE CERAMICHE SONO REALIZZATE IN TOSCANA, PER COLAGGIO, CON TERRE BIANCHE. PER LA DECORAZIONE SONO STATI USATI 18 SMALTI FRA LUCIDI E OPACHI E 3 COLORI ACRILICI, TUTTI APPLICATI ALL'AREOGRAFO.

OGNI SMALTO HA DETERMINATO UNA PROPRIA COTTURA A TEMPERATURE CHE VANNO DA 680°C PER IL TERZO FUOCO A 960° C PER LO SMALTO A GRAN FUOCO.

I COLORI ACRILICI NON SONO STATI SOTTOPOSTI A COTTURA.

TALVOLTA, PER ASSEMBLARE LE PARTI IN CERAMICA DI UNO STESSO OGGETTO, SONO STATE UTILIZZATE COLLE E TIRANTI.

I VETRI

TUTTI I VETRI SONO REALIZZATI A MURANO, SOFFIATI A BOCCA NEI TRADIZIONALI STAMPI DI LEGNO. L'UNICA ECCEZIONE È "GRIFONE" LA CUI FORMA NON CIRCOLARE HA RICHIESTO L'UTILIZZO DI UNO STAMPO IN METALLO.

I COLORI UTILIZZATI SONO 8 TUTTI DI PRODUZIONE ESCLUSIVA DELLA FORNACE.

IN ALCUNI CASI IL MAESTRO È RICORSO A TECNICHE PARTICOLARI COME L'INCALMO, L'INCAMICIATURA E LA MORISA.

INCALMO: ANTICA TECNICA VENEZIANA, RICHIEDE GRANDE ABILITÀ DA PARTE DEL MAESTRO CHE DEVE FAR COMBACIARE A CALDO DUE CILINDRI DI UGUALE DIAMETRO E SPESSORE IN MODO DA REALIZZARE UN OGGETTO CON DUE O PIÙ FASCE DI COLORI DIVERSI.

VETRO INCAMICIATO: È COSTITUITO DA UNO STRATO ESTERNO CHE SI SOVRAPPONE AD UNO STRATO INTERNO DI COLORE DIVERSO.

MORISA: DECORAZIONE A CALDO OTTENUTA CON UN CORDONCINO DI VETRO CHE DEVE ESSERE POSIZIONATO ALLO STATO PLASTICO SUL PEZZO DA DECORARE.

IL MARCHIO

TUTTI I 14 OGGETTI HANNO RIPORTATO IN DECALCOMANIA, NELLA PARTE DI CERAMICA IL NOME DELLA COLLEZIONE, L'ANNO DI PRODUZIONE, LA FIRMA DELL'AUTORE E LA NUMERAZIONE PROGRESSIVA.

2003
SHORT STORIES BY
EMERSON
HAND MADE IN ITALY

/33

I VETRI PORTANO INCISO MANUALMENTE IL NOME DELLA COLLEZIONE, LA FIRMA DELL'AUTORE, LA NUMERAZIONE PROGRESSIVA E MURANO COME LUOGO DI PRODUZIONE.

OGNI OGGETTO SARÀ ACCOMPAGNATO DA UNA GARANZIA DOVE VIENE IDENTIFICATO IL MODO DI PRODUZIONE, LA NUMERAZIONE PROGRESSIVA E LE PROVE D'AUTORE CHE SI SONO RESE NECESSARIE PER LA DEFINIZIONE DELLA FORMA E DEI COLORI.



CERAMICS

ALL CERAMICS HAVE BEEN PRODUCED IN TUSCANY BY CASTING WITH WHITE EARTHS. THEY HAVE BEEN DECORATED BY USING 18 GLAZES BOTH GLOSSY AND MATT AND 3 ACRYLIC, COLOURS APPLIED BY MEANS OF A SPRAY GUN. EACH GLAZE HAS ITS OWN BAKING TIME AT TEMPERATURES RANGING FROM 680°C FOR THE THIRD BAKING TO 960°C FOR THE GLAZE AT HIGH TEMPERATURE. THE ACRYLIC COLOURS DO NOT UNDERGO ANY BAKING PROCESS. SOMETIMES TO ASSEMBLE THE CERAMIC PARTS OF AN ITEM SPECIAL GLUES HAVE BEEN USED.

GLASSES

ALL GLASSES HAVE BEEN PRODUCED IN MURANO AND BLOWN USING THE TRADITIONAL WOODEN MOULDS EXCEPT FOR "GRIFONE" WHICH, DUE TO ITS NON-CIRCULAR SHAPE, HAS BEEN MADE USING A METAL MOULD. ALL THE 8 COLOURS ARE AN EXCLUSIVE PRODUCE OF THE FURNACE. IN SOME CASES THE MAESTRO HAS USED SPECIAL GLASSMAKING TECHNIQUES SUCH AS THE INCALMO, INCAMICIATURA AND MORISA. INCALMO: IS AN ANCIENT VENETIAN TECHNIQUE WHICH ENTAILS THE MAESTRO'S GREAT ABILITY TO FIT TOGETHER AT HIGH TEMPERATURES TWO CYLINDERS HAVING THE SAME DIAMETER AND THICKNESS IN ORDER TO CREATE AN OBJECT HAVING TWO OR MORE BANDS WITH DIFFERENT COLOURS. VETRO INCAMICIATO: IS A SPECIAL GLASS CHARACTERIZED BY AN EXTERNAL LAYER FITTED ONTO AN INTERNAL LAYER HAVING DIFFERENT COLOURS. MORISA: IS A HOT-DECORATION OBTAINED BY USING A GLASS STRING THAT MUST BE APPLIED IN ITS PLASTIC STATE ONTO THE OBJECT.

THE TRADEMARK

ALL THE 14 ITEMS HAVE A DECALCOMANIA IN THEIR CERAMIC PART SHOWING THE NAME OF THE COLLECTION, THE YEAR OF PRODUCTION, THE AUTHOR'S NAME AND THE PROGRESSIVE NUMBER.

2003
SHORT STORIES BY
ETIORESON
HAND MADE IN ITALY

/33

THE GLASSES ARE HAND-ENGRAVED WITH THE NAME OF THE COLLECTION, THE AUTHOR'S NAME, THE PROGRESSIVE NUMBER AND MURANO AS PRODUCTION PLACE. EACH ITEM HAS A GUARANTEE INDICATING THE PRODUCTION TECHNIQUES, THE PROGRESSIVE NUMBER AND THE AUTHOR'S PROOFS WHICH WERE NECESSARY TO DEFINE THE SHAPE AND COLOURS.

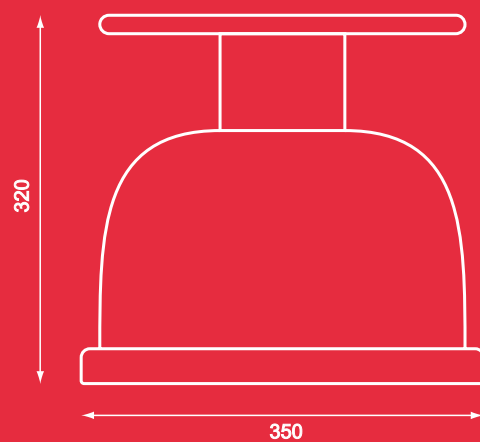

CUCULO > VASO IN CERAMICA E VETRO IN EDIZIONE LIMITATA A 33 ESEMPLARI E 5 PROVE D'AUTORE. CERAMICA SMALTATA IN ROSSO CINABRO LUCIDO, BASE IN BIANCO OPACO. VETRO GIALLO A "INCALMO" NERO, SOFFIATO A MURANO.

CUCULO CERAMIC AND GLASS VASE IN LIMITED EDITION OF 33 PIECES AND 5 AUTHOR'S PROOFS. GLAZED CERAMIC, CINNABAR RED, WITH MATT WHITE BASE. YELLOW GLASS WITH BLACK "INCALMO", BLOWN IN MURANO.

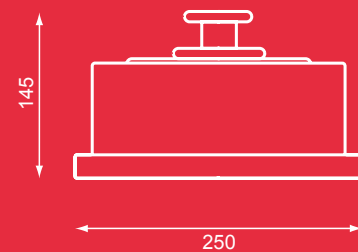

MERLO > SCATOLA IN CERAMICA IN EDIZIONE LIMITATA A 33 ESEMPLARI E 4 PROVE D'AUTORE. COPERCHIO, BASE E INTERNO SMALTATI IN NERO LUCIDO, CORPO DECORATO CON COLORE ACRILICO IN "GIALLO FLUORESCENTE".

MERLO CERAMIC BOX IN LIMITED EDITION OF 33 PIECES AND 4 AUTHOR'S PROOFS. GLAZED BASE, INSIDE AND LID, GLAZED BLACK KNOB, DECORATED BODY IN ACRYLIC "FLUORESCENT YELLOW".

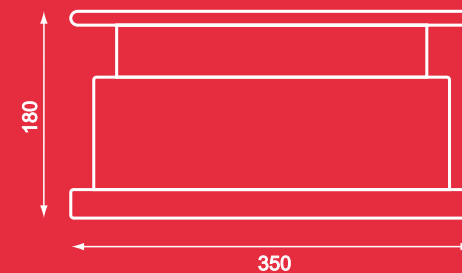

TORTORA > FRUTTIERA IN CERAMICA E VETRO IN EDIZIONE LIMITATA A 33 ESEMPLARI E 3 PROVE D'AUTORE. CERAMICA SMALTATA IN BIANCO OPACO, INTERNO NERO LUCIDO, BORDO VERDE LUCIDO. VETRO GIALLO A "INCALMO" ROSA, SOFFIATO A MURANO.

TORTORA CERAMIC AND GLASS FRUIT BOWL IN LIMITED EDITION OF 33 PIECES AND 3 AUTHOR'S PROOFS. GLAZED CERAMIC, MATT WHITE, GLOSSY BLACK INSIDE, GLOSSY GREEN EDGE. YELLOW GLASS WITH PINK "INCALMO", BLOWN IN MURANO.

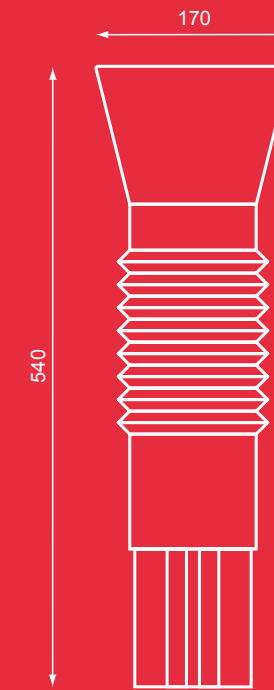

GANGA > VASO IN CERAMICA, VETRO E METALLO IN EDIZIONE LIMITATA A 33 ESEMPLARI E 3 PROVE D'AUTORE. CERAMICA SMALTATA IN GRIGIO LUCIDO E NERO OPACO. BASE IN METALLO VERNICIATO IN NERO OPACO. VETRO "INCAMICIATO" VERDE CON PICCOLE INCLUSIONI DI BOLLE D'ARIA, SOFFIATO A MURANO.

GANGA CERAMIC, GLASS AND METAL VASE IN LIMITED EDITION OF 33 PIECES AND 3 AUTHOR'S PROOFS. GLAZED CERAMIC IN GLOSSY GREY AND MATT BLACK. BASE IN MATT BLACK METAL. "INCAMICIATO" GREEN GLASS WITH LITTLE AIR BUBBLES, BLOWN IN MURANO.

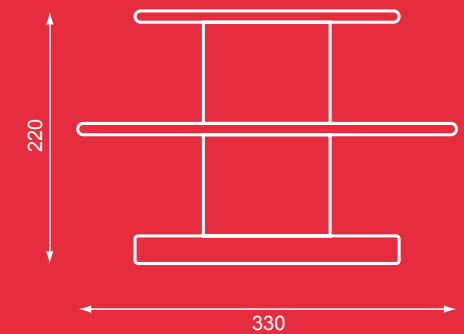

PETTIROSSO > VASO IN CERAMICA E VETRO IN EDIZIONE LIMITATA A 33 ESEMPLARI E 5 PROVE D'AUTORE. CERAMICA SMALTATA IN "BRUNO VANDYKE" OPACO, NERO LUCIDO E NERO OPACO. VETRO ROSSO SOFFIATO A MURANO.

PETTIROSSO CERAMIC AND GLASS VASE IN LIMITED EDITION OF 33 PIECES AND 5 AUTHOR'S PROOFS. GLAZED CERAMIC IN MATT "BRUNO VANDYKE", GLOSSY AND MATT BLACK. RED GLASS BLOWN IN MURANO.

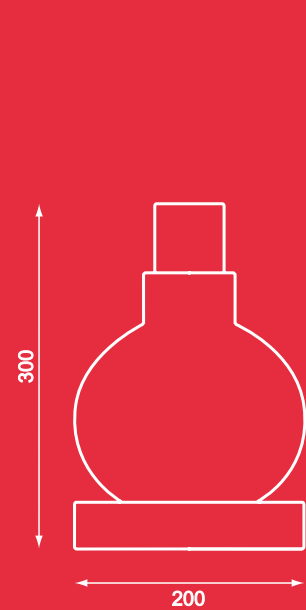

GRIFONE > VASO IN CERAMICA E VETRO IN EDIZIONE LIMITATA A 33 ESEMPLARI E 3 PROVE D'AUTORE.
CERAMICA SMALTATA IN NERO LUCIDO E VERDE OPACO, BASE BIANCO OPACO.
VETRO DI MURANO "VERDE LAURO" SOFFIATO A FERMO MOLATO E LUCIDATO SU TUTTI I LATI.

GRIFONE CERAMIC AND GLASS VASE IN LIMITED EDITION OF 33 PIECES AND 3 AUTHOR'S PROOFS.
GLAZED CERAMIC, GLOSSY BLACK AND MATT GREEN, MATT WHITE BASE.
MURANO GLASS, "LAUREL GREEN", BLOWN IN A METAL MOULD, GRINDED AND POLISHED ON ALL SIDES.

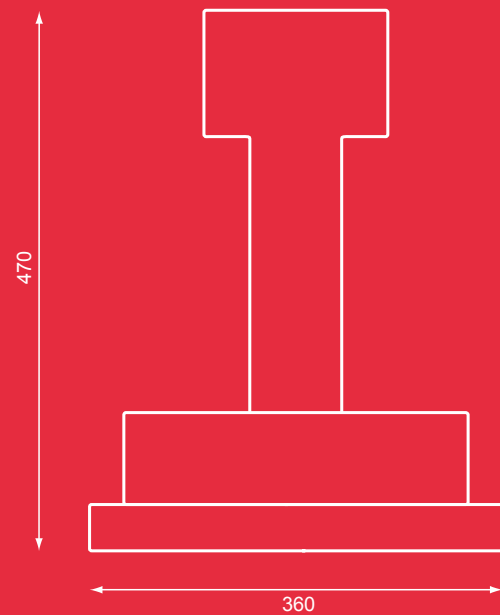

IBIS > VASO IN CERAMICA E VETRO IN EDIZIONE LIMITATA A 33 ESEMPLARI E 4 PROVE D'AUTORE.
CERAMICA SMALTATA IN BLU COBALTO, INTERNO NERO LUCIDO, BASE IN BIANCO OPACO.
VETRO "VERDE LAURO" SOFFIATO A MURANO.

IBIS CERAMIC AND GLASS VASE IN LIMITED EDITION OF 33 PIECES AND 4 AUTHOR'S PROOFS.
GLAZED CERAMIC, MATT COBALT BLUE, GLOSSY BLACK INSIDE, MATT WHITE BASE.
"LAUREL GREEN" GLASS BLOWN IN MURANO.

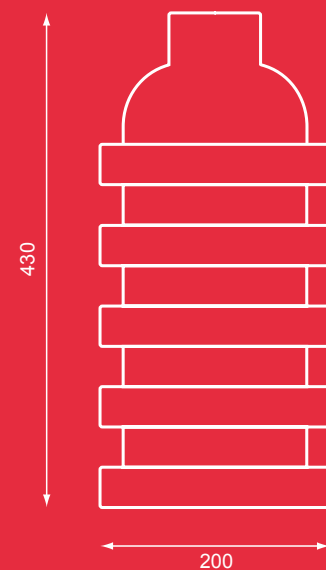

CIVETTA > VASO IN CERAMICA IN EDIZIONE LIMITATA A 33 ESEMPLARI E 3 PROVE D'AUTORE.
CERAMICA SMALTATA IN NERO LUCIDO, BIANCO LUCIDO E ROSSO OPACO.
PARTE SUPERIORE SMALTATA "SABBIA" OPACO.

CIVETTA CERAMIC VASE IN LIMITED EDITION OF 33 PIECES AND 3 AUTHOR'S PROOFS.
GLAZED CERAMIC, GLOSSY BLACK, GLOSSY WHITE AND MATT RED.
GLAZED UPPER PART, MATT SANDY.



PICCHIO > FRUTTIERA IN CERAMICA IN EDIZIONE LIMITATA A 33 ESEMPLARI E 3 PROVE D'AUTORE.
BASE SMALTATA IN NERO E BIANCO LUCIDO, SOLIDI SOVRASTANTI IN BIANCO OPACO.

PICCHIO CERAMIC FRUIT BOWL IN LIMITED EDITION OF 33 PIECES AND 3 AUTHOR'S PROOFS.
GLAZED BASE IN GLOSSY BLACK AND WHITE, THE ELEMENTS IN THE UPPER PART ARE IN MATT WHITE.

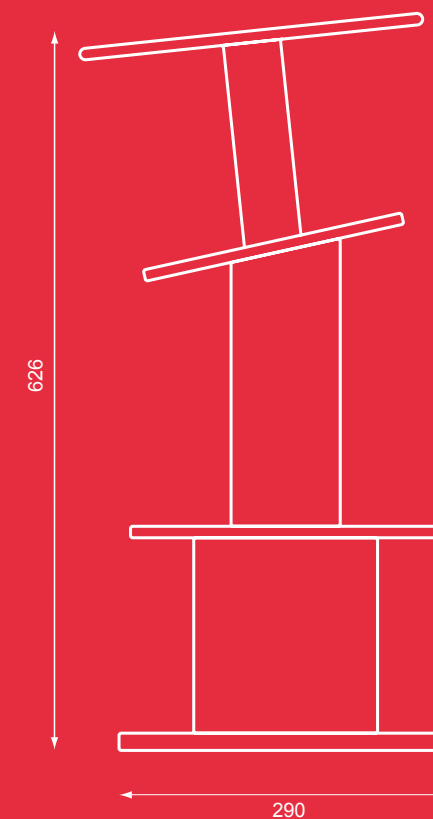

UPUPA > VASO IN CERAMICA E VETRO IN EDIZIONE LIMITATA A 33 ESEMPLARI E 5 PROVE D'AUTORE.
CERAMICA SMALTATA IN BIANCO OPACO E ROSSO CINABRO LUCIDO. LA PARTE CENTRALE È DECORATA CON COLORE ACRILICO IN "ROSA FLUORESCENTE".
VETRO GIALLO SOFFIATO A MURANO

UPUPA CERAMIC AND GLASS VASE IN LIMITED EDITION OF 33 PIECES AND 5 AUTHOR'S PROOFS.
GLAZED CERAMIC, MATT WHITE AND GLOSSY CINNABAR RED. THE MIDDLE PART IS DECORATED IN ACRYLIC "FLUORESCENT PINK".
YELLOW GLASS BLOWN IN MURANO.

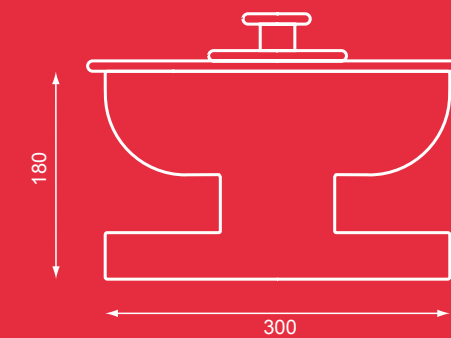

TORDO > SCATOLA IN CERAMICA IN EDIZIONE LIMITATA A 33 ESEMPLARI E 5 PROVE D'AUTORE.
COPERCHIO SMALTATO BIANCO OPACO CON POMOLO NERO LUCIDO, CORPO BICOLORE VERDE E BIANCO OPACO, INTERNO NERO LUCIDO.

TORDO CERAMIC BOX IN LIMITED EDITION OF 33 PIECES AND 5 AUTHOR'S PROOFS.
GLAZED LID, MATT WHITE WITH GLOSSY BLACK KNOB, MATT GREEN AND WHITE BODY, GLOSSY BLACK INSIDE.

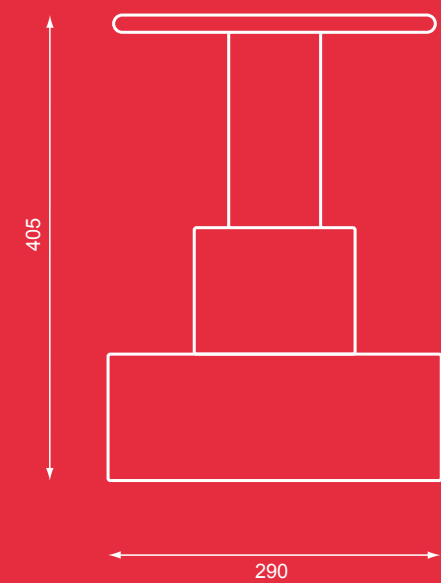

MARABÙ > VASO IN CERAMICA E VETRO IN EDIZIONE LIMITATA A 33 ESEMPLARI E 3 PROVE D'AUTORE.
CERAMICA SMALTATA IN BIANCO OPACO PERLACEO.
VETRO NERO SOFFIATO A MURANO.

MARABÙ CERAMIC AND GLASS VASE IN LIMITED EDITION OF 33 PIECES AND 3 AUTHOR'S PROOFS.
GLAZED CERAMIC IN MATT WHITE PEARL.
BLACK GLASS BLOWN IN MURANO.

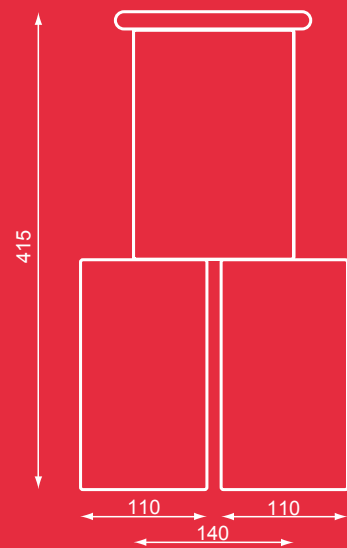

AIRONE > VASO IN CERAMICA E VETRO IN EDIZIONE LIMITATA A 33 ESEMPLARI E 3 PROVE D'AUTORE.
CERAMICA SMALTATA IN NERO OPACO E NERO LUCIDO.
IL DISCO SUPERIORE DEI QUATTRO CILINDRI DI BASE È DECORATO CON COLORE ACRILICO IN "ROSSO FLUORESCENTE".

VETRO SETA CON "MORISA" CON PICCOLE INCLUSIONI DI BOLLE D'ARIA, SOFFIATO A MURANO.

AIRONE CERAMIC AND GLASS VASE IN LIMITED EDITION OF 33 PIECES AND 3 AUTHOR'S PROOFS.
GLAZED CERAMIC, MATT AND GLOSSY BLACK. THE UPPER DISC OF THE FOUR MAIN CYLINDERS IS DECORATED IN ACRYLIC "FLUORESCENT RED".
SILK GLASS WITH "MORISA" AND LITTLE AIR BUBBLES, BLOWN IN MURANO.

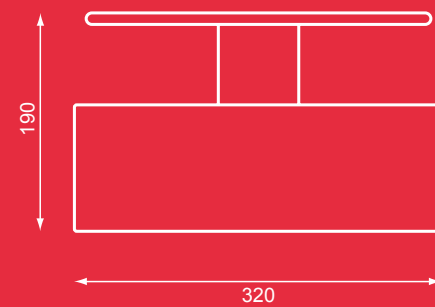

ALLODOLA > VASO IN CERAMICA E VETRO IN EDIZIONE LIMITATA A 33 ESEMPLARI E 3 PROVE D'AUTORE.
CERAMICA DECORATA CON COLORE ACRILICO IN "ROSA FLUORESCENTE".
VETRO GRIGIO SOFFIATO A MURANO.

ALLODOLA CERAMIC AND GLASS VASE IN LIMITED EDITION OF 33 PIECES AND 3 AUTHOR'S PROOFS.
CERAMIC DECORATED WITH ACRYLIC "FLUORESCENT PINK".
GREY GLASS BLOWN IN MURANO.

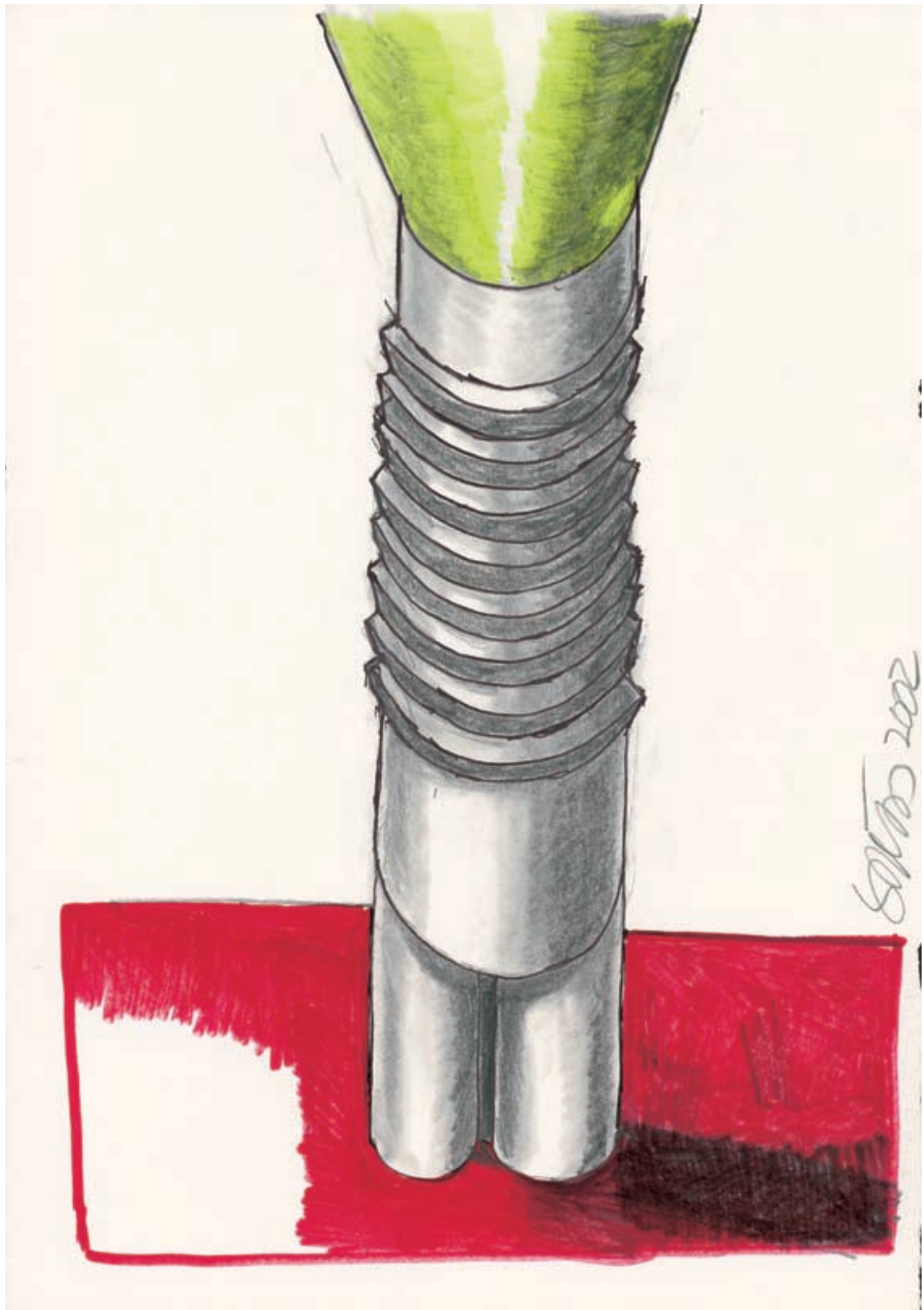

SAINTS 2002

LA COLLEZIONE "QUATTORDICI CERAMICHE E VETRI" DI ETTORE SOTTASS E' PRODOTTA E DISTRIBUITA DA
SHORT STORIES – LIVORNO IN UNA EDIZIONE DI 33 PEZZI NUMERATI E FIRMATI.

THE COLLECTION "FOURTEEN CERAMICS AND GLASSES" BY ETTORE SOTTASS IS PRODUCED AND
DISTRIBUTED BY SHORT STORIES – LIVORNO IN A LIMITED EDITION OF 33 NUMBERED AND SIGNED PIECES.

ASSISTENZA AL PROGETTO
PROJECT ASSISTANCE
ARCH. ELENA CUTOLO

GRAFICA
GRAPHICS
MIRABEAU

FOTO
PHOTOS
RICCARDO BIANCHI

FOTO DELLE PROVE D'AUTORE
PHOTOS OF AUTHOR'S PROOFS
MIRABEAU

FOTO DEL MAESTRO VETRAIO
PHOTOS OF MASTER GLASS-MAKER
ARCH. CLAUDIO MARTURANO

FOTO DEL MAESTRO CERAMISTA
PHOTOS OF MASTER CERAMIC-MAKER
MIRABEAU

VETRI SOFFIATI
BLOWN GLASSES
SERGIO PIOZZO – MURANO
CONSULENZA ARCH. CLAUDIO MARTURANO

MAESTRO CERAMISTA
MASTER CERAMIC-MAKER
MAURO E SERGIO

PUBBLICATO DA BELFORTE EDITORI LIBRAI DAL 1805 - LIVORNO
STAMPATO DA SACCARDO - ORNAVASSO (VB) NEL MESE DI MARZO 2003
EDIZIONE LIMITATA A 1.333 COPIE

EDITED BY BELFORTE EDITORI LIBRAI DAL 1805 - LIVORNO
PRINTED BY SACCARDO - ORNAVASSO (VB) ON MARCH 2003
LIMITED EDITION TO 1.333 COPIES

/1.333